

A SYNTACTICAL ANALYSIS IN NON-STANDARD ENGLISH WORD OF MAC MILLER SONG LYRICS

Ardina Arifin
Joko Wibowo

Islamic Institute of al-Qolam Malang
jokowibowo@alqolam.ac.id

Abstract

Every human being has at least one language, both spoken and written. The language contains basic or certain rules that form, combine, and express meaning that changes because words in language are combined differently through combinations in syntactic studies so that language has an important role in human life as a means of communication. This is actually the realization of the written examples. The Purpose of this research was to find out the non-standard and standard English words and to find out the tree structure in the Mac Miller song lyrics. Then, the writer chooses songs to analyze because studying songs does not just analyze the metaphors language, word meaning and language style, but also analyze how non-standard English words can be used as standard English words by converting them with several tools such as phonological processes and basic grammar which in the song the English standard has been found the writer analyzes sentence structure used in one of the lyrics to a song from Mac Miller's album entitled "Circles". In analyzing the data, the writer uses several appropriate theories with a subject for analyze sentences into each sentence content. This thesis uses a qualitative descriptive method. Steps in taking and the data collection are listening songs on the album "Circles" by Mac Miller, searching the lyrics of the internet, copying the lyrics of the songs to be analyzed, reading and identifying the non-standard English word and converted into standard English word using instrument for standardizing English words and the last make tree structure from the sentence or phrase. Moreover, the result after analyzing the data, the writer finally found fifteen rules in sentence structure and found thirty non-standard English word sentences in the lyrics of the song. Considering the importance of understanding sentence structure, especially in the study of syntax, the writer makes some suggestions, for students from English Department, other researcher who will conduct studies related to topics and the writer hopes that this thesis can be used as a reference or compare how non-standard English with their daily non-standard language and for those who are interested in studying syntax studies.

Keywords: Syntactical Analysis, Non-Standard English Words, Mac Miller, and Song Lyric

INTRODUCTION

The study of syntactic structure in song lyrics becomes more important when words or lexical items are combined into cohesive sentences so that in song lyrics sometimes writers or listeners find words that have different interpretations in the form of sentence structure, therefore the writer concludes the importance of structural studies sentences in song lyrics.

In order to understand ambiguous words in non-standard English, it is necessary to convert them into standard words using phonological process and basic grammar and one of the proper ways to understand the sentence structure is to use a tree structure. The writer uses analysis using a tree structure because the analysis is deeper than grammar only, it means tree structure through a syntactic analysis process, according to the meaning to Radford, tree structure is a type of graph used to indicate the syntactic structure of a phrase or sentence. There are other reasons studying syntax, from English student or other major student other major students who like the field of syntax to much more specific aims, namely to help the students clarify the patterns of English more effectively and evidently and to enable the student to consideration the structure of English sentences in an organized and explicit way. Language contains basic

fundamentals or definite rules that form, combine, and express changed meanings because words in the language are combined differently through combinations in the study of syntax.

METHOD

This research belongs to descriptive qualitative research because the data are presented in the form words not numbers. Besides, the data are interpreted and displayed descriptively and systematically based on the supporting theory from the object of the study and this method of research that attempt to describe and interpret the object in accordance with reality.

FINDING

The writer will display the data display that will be examined in this study. Data display is where data are organized.¹ Miles, Huberman, and Saldana mention that a display is an organized, compressed assembly of information that allows conclusion drawing and action. In this study, the writer will display the song lyrics that contain Non-standard English word, and converted it in Standard English Word, then put the sentence into a table.

Non-Standard English	Instrument For Standardizing English Words	Standard English Word
Song Lyrics Non-Standard English Word (line)	Instrument For Standardizing English Words	Song Lyrics Standard English Word

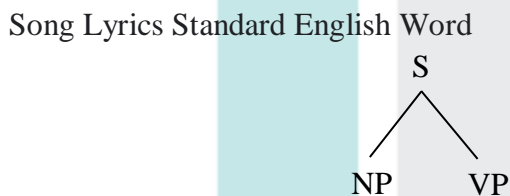

In the song lyrics, writer found some Non-Standard English and Instrument for Standardizing English Words which can be written line by line in the following table:

1. Song lyric title: COMPLICATED

Datum 1:

Non-Standard English	Instrument For Standardizing English Words	Standard English Word
Behind the wheel, but still ain't on my way (line 2)	<ul style="list-style-type: none"> - Phonological process: Delection of the Negations - Basic Grammar: Using Be: Pronoun+Be+No un 	Behind the wheel, but I am still not on my way

¹Ulfa Muti'ah Fuad, "A Syntactic Analysis of Sentence Pattern Used in Westlife's Song Lyrics", *Thesis* (Medan: University of Sumatera Utara, 2021), page 28.

Behind the wheel, but I am still not on my way

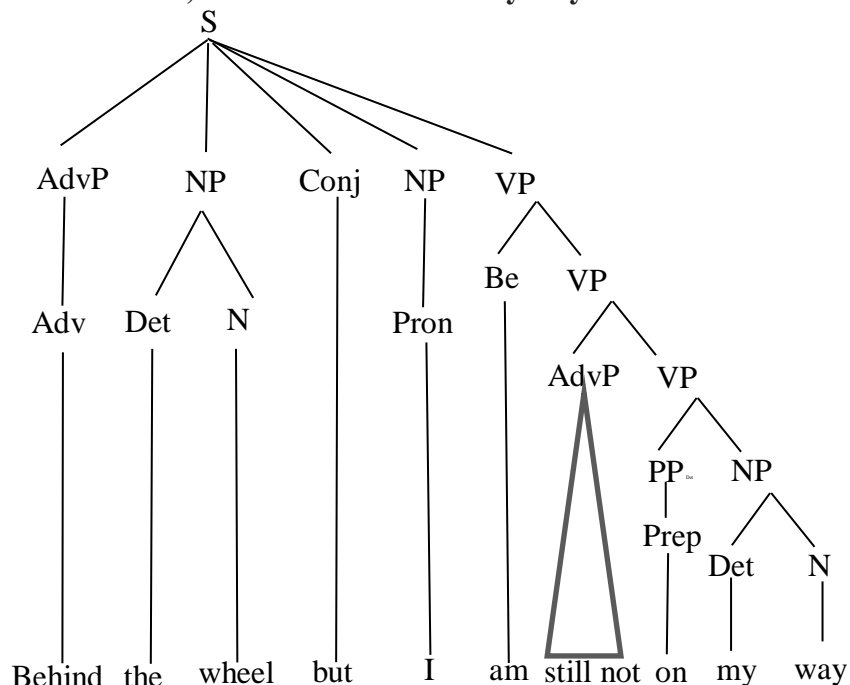

The rules of the tree structure is : $S \rightarrow AdvP + NP + Conj + NP + VP$

Based on the tree structure, sentence (Behind the wheel, but I am still not on my way) consist of AdvP plus NP plus Conj NP plus VP. Adverb Phrase consist of adverb (behind) plus Noun Phrase consist of determiner (the) and noun (wheel) plus Conjunction (but) plus Noun Phrase consist of pronoun (I) plus Verb Phrase consist of Be (am), Adverb Phrase (still not), Preposition Phrase consist of Preposition (on), Noun Phrase consist of determiner (my) and Noun (way).

Datum 2:

Non-Standard English	Instrument For Standardizing English Words	Standard English Word
Does it always gotta, does it always gotta (line 6)	Phonological process: Assimilation	It is always got to be so complicated

It is always got to be so complicated

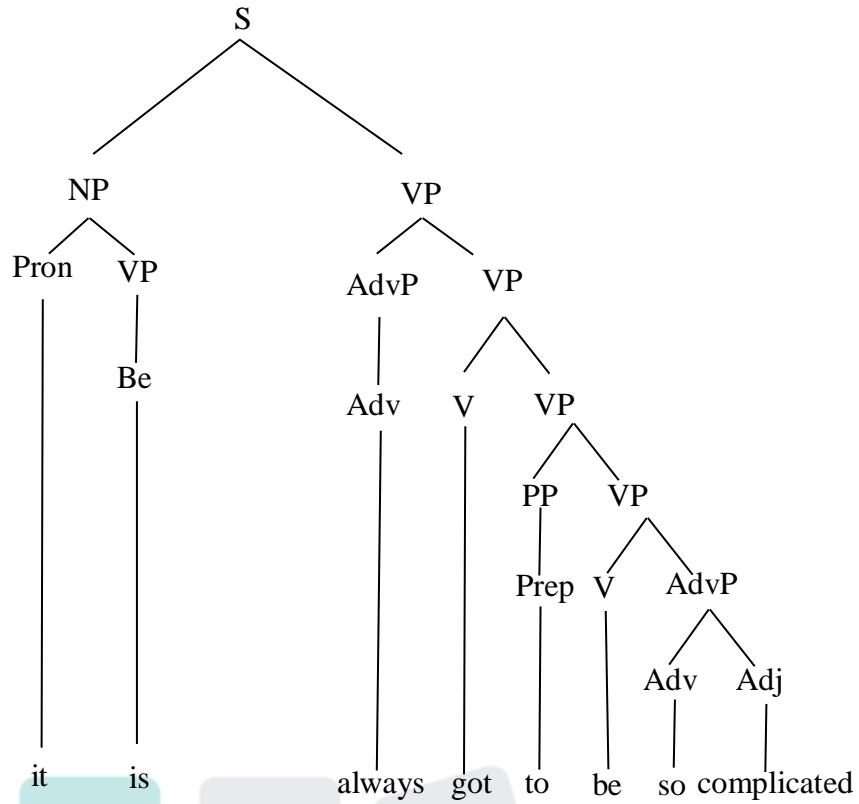

The rules of the tree structure is : $S \rightarrow NP + VP$

Based on the tree structure, sentence (It is always got to be so complicated) consist of NP plus VP. Noun Phrase consist of pronoun (it) and Verb Phrase consist of Be (is) plus Verb Phrase consist of Adverb Phrase consist of adverb (always), Verb (got), Preposition Phrase consist of Preposition (to), Verb (be), Adverb Phrase consist of adverb (so) and adjective (complicated).

Datum 3:

Non-Standard English	Instrument For Standardizing English Words	Standard English Word
Mm, and all I wanna do is look, but I can't see, baby (line 8)	<ul style="list-style-type: none"> - Phonological process: Assimilation - Phonological process: Delection of the Negations 	And all I want to look, but I can not see, baby

And all I want to look, but I can not see, baby

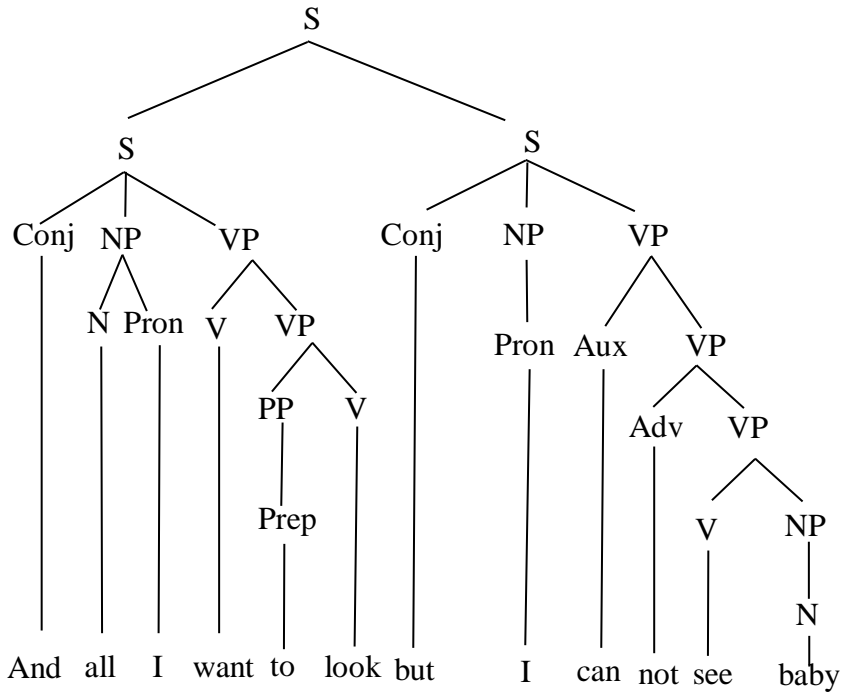

The rules of the tree structure is : $S_1 \rightarrow \text{Conj} + \text{NP} + \text{VP}$

$S_2 \rightarrow \text{Conj} + \text{NP} + \text{VP}$

Based on the tree structure, sentence (And all I want to look, but I can not see, baby) consist of First Sentence consist of Conj plus NP plus VP and Second Sentence Conj plus NP plus VP. First Sentence consist of conjunction (and) plus Noun Phrase consist of Noun (all), Pronoun (I) plus Verb Phrase consist of Verb (want), Preposition Phrase consist of Preposition (to), Verb (look). And Second Sentence consist of conjunction (but) plus Noun Phrase consist of pronoun (I) plus Verb Phrase consist of Auxiliary (can), Adverb (not), Verb (see), and Noun Phrase consist of Noun (Baby).

Datum 4:

Non-Standard English	Instrument For Standardizing English Words	Standard English Word
'Fore I start to think about the future (line 15)	- Phonological process: Deletion in Aphesis	Before I start to think about the future

Before I start to think about the future

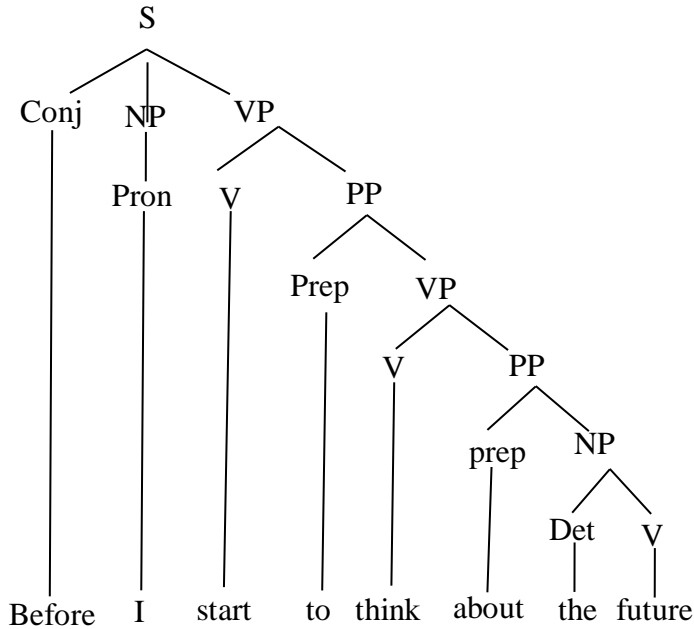

The rules of the tree structure is : $S \rightarrow \text{Conj} + \text{NP} + \text{VP}$

Based on the tree structure, sentence (Before I start to think about the future) consist of Conj plus NP plus VP. Conjunction (Before) plus Noun Phrase consist of pronoun (I) plus Verb Phrase consist of Verb (start), Preposition Phrase consist of Preposition (to), Verb (think), Preposition Phrase consist of Preposition (about), Noun Phrase consist of Determiner (the) and Noun (future).

2. Song lyric title: BLUE WORDS

Datum 5:

Non-Standard English	Instrument For Standardizing English Words	Standard English Word
I ain't politickin', I ain't kissin' no babies (line 5)	- Phonological process: Delection of the Negations	I am not a politician and no kissing the baby

I am not a politician and no kissing the baby

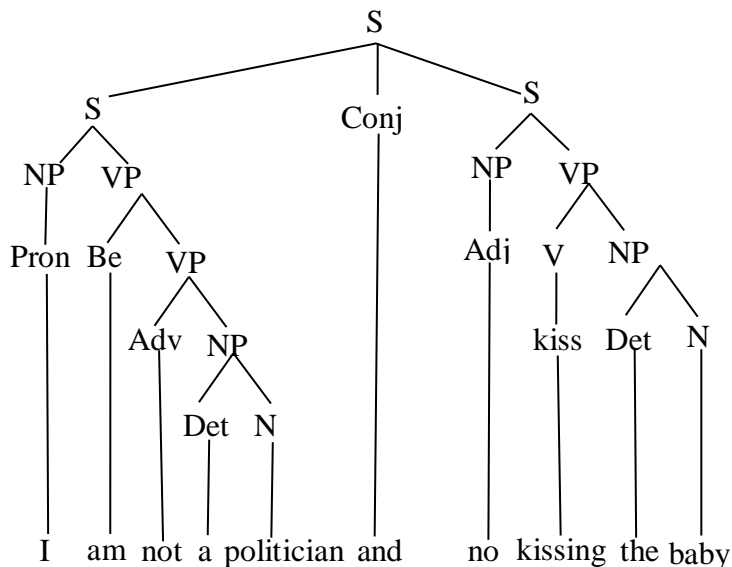

The rules of the tree structure is : $S_1 \rightarrow NP + VP$

Conj

$S_2 \rightarrow NP + VP$

Based on the tree structure, sentence (I am not a politician and no kissing the baby) consist of First Sentence consist of NP plus VP, Conj, and Second Sentence NP plus VP. First Sentence consist of Noun Phrase consist of Pronoun (I) Plus Verb Phrase consist of Be (am), Adverb (not), Noun Phrase consist of Determiner (a) and Noun (politician) plus Conjunction (and) plus Noun Phrase consist of adjective (no), Plus Verb Phrase consist of Verb (kissing), Noun Phrase consist of Determiner (the) and Noun (baby).

Datum 6:

Non-Standard English	Instrument For Standardizing English Words	Standard English Word
We don't gotta let him in, don't trip (line 8)	<ul style="list-style-type: none"> - Phonological process: Delection of the Negations - Phonological process: Assimilation 	We have not got to let him on the trip

We have not got to let him on the trip

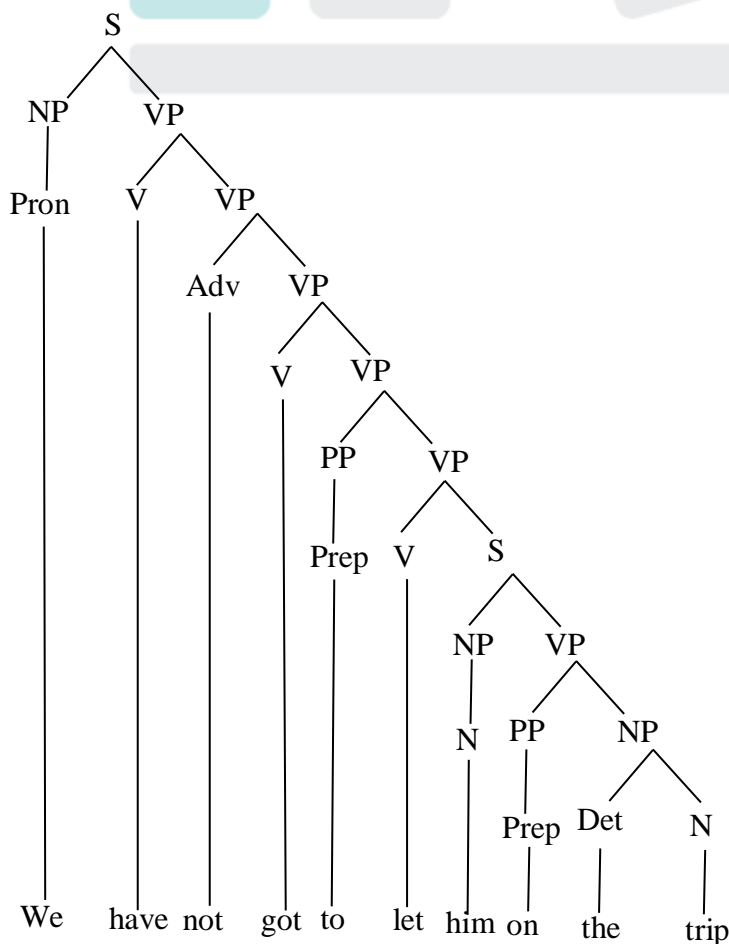

The rules of the tree structure is : $S \rightarrow NP + VP$

Based on the tree structure, sentence (We have not got to let him on the trip) consist of NP plus VP. Noun Phrase consist of Pronoun (we) Plus Verb Phrase consist of Verb (have), Adverb (not), Verb (got), Preposition Phrase consist of Preposition (to), Verb (let), Sentence consist of Noun Phrase consist of Noun (him), Verb Phrase consist of Preposition Phrase consist of Preposition (on), Noun Phrase consist of Determiner (the) and Noun (trip).

Datum 7:

Non-Standard English	Instrument For Standardizing English Words	Standard English Word
We ain't even worried, we just laughin', that's rich (line 20)	- Phonological process: Delection of the Negations	We are not worried, but we just laugh

We are not worried, but we just laugh

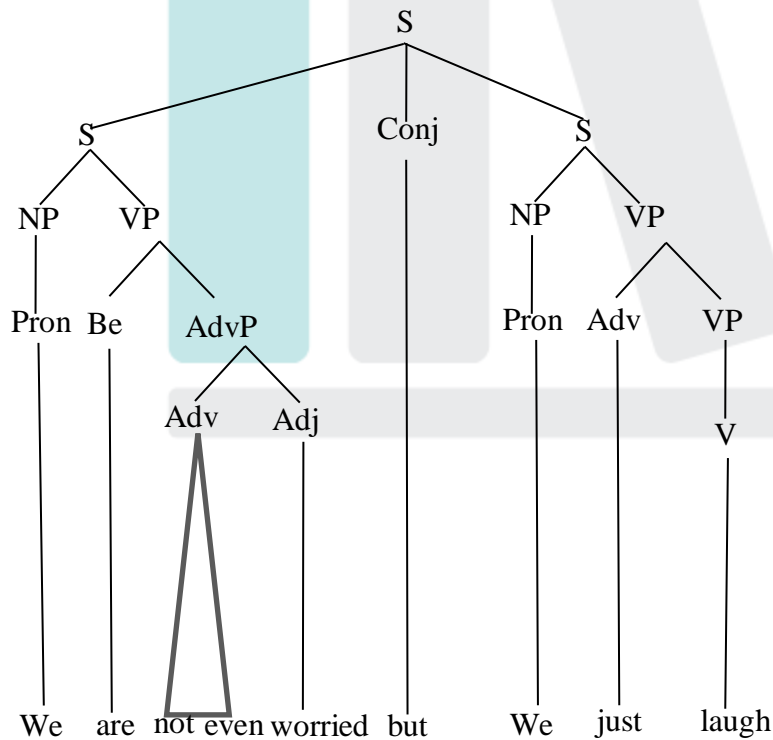

The rules of the tree structure is : $S1 \rightarrow NP + VP$

Conj

$S2 \rightarrow NP + VP$

Based on the tree structure, sentence (We are not worried, but we just laugh) consist of First Sentence consist of NP plus VP, Conj, and Second Sentence consist of NP plus VP. First Sentence consist of Noun Phrase consist of Pronoun (we) Plus Verb Phrase consist of Be (are), Adverb Phrase consist of Adverb (not) and Adjective

(worried). Conjunction (but) and Second Sentence consist of Noun Phrase consist of Pronoun (we), Plus Verb Phrase consist of Verb (laugh).

Datum 8:

Non-Standard English	Instrument For Standardizing English Words	Standard English Word
You know how it goes, it ain't broke, don't fix (line 21)	- Phonological process: Delection of the Negations	You know how it goes, it is not broken, do not fix

You know how it goes, it is not broken, do not fix

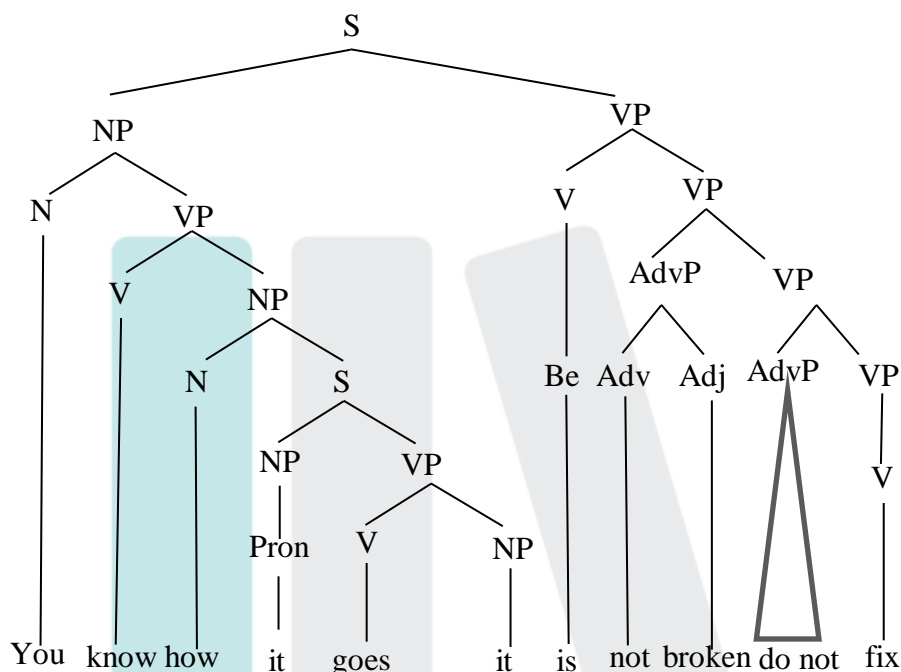

The rules of the tree structure is : $S \rightarrow NP + VP$

Based on the tree structure, sentence (You know how it goes, it is not broken, do not fix) consist of NP plus VP. Noun Phrase consist of Pronoun (you), Verb Phrase consist of Verb (know), Noun Phrase consist of Noun (how), sentence consist of Noun Phrase consist of Pronoun (it), Verb Phrase consist of Verb (goes), and Noun Phrase (it) plus Verb Phrase consist of Verb (is), Adverb Phrase consist of Adverb (not) and Adjective (broken), Adverb Phrase (do not), Verb (fix).

Datum 8:

Non-Standard English	Instrument For Standardizing English Words	Standard English Word
No, I ain't God, but I'm feelin' just like Him (line 27)	- Phonological process: Delection of the Negations	No, I am not God, but I feel like Him

No, I am not God, but I feel like Him

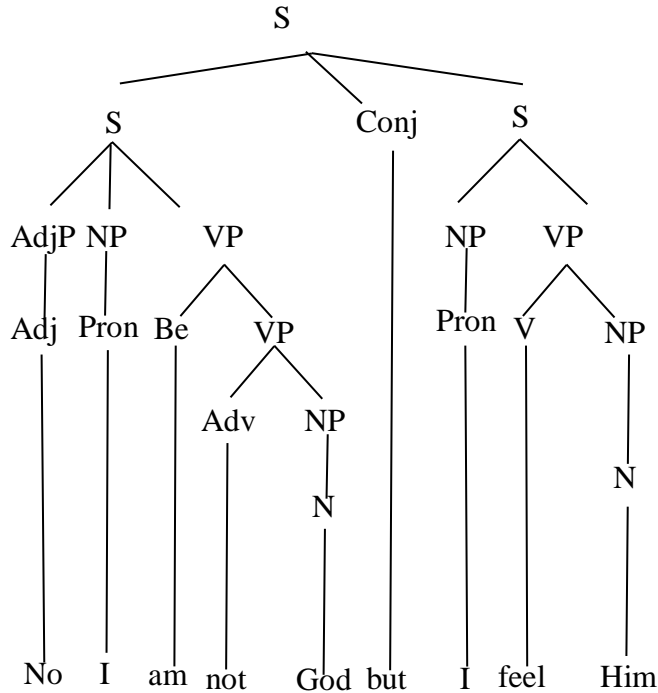

The rules of the tree structure is : $S_1 \rightarrow \text{AdjP} + \text{NP} + \text{VP}$

Conj

$S_2 \rightarrow \text{NP} + \text{VP}$

Based on the tree structure, sentence (No, I am not God, but I feel like Him) consist of First Sentence consist of AdjP plus NP plus VP, Conjunction, and Second Sentence Conj plus NP plus VP. First Sentence consist of Adjective Phrase consist of Adjective (no) Plus Noun Phrase consist of Pronoun (I) plus Verb Phrase consist of Be (am), Adverb (not), Noun Phrase consist of Noun (God). Conjunction (but) plus Noun Phrase consist of Pronoun (I) plus Verb Phrase consist of Verb (feel) and Noun Phrase consist of Noun (him).

3. Song lyric title: GOOD NEWS

Datum 9:

Non-Standard English	Instrument For Standardizing English Words	Standard English Word
But it ain't stealing, can I get a break? (line 12)	- Phonological process: Delection of the Negations	But it is not stealing, can I get a break?

But it is not stealing, can I get a break?

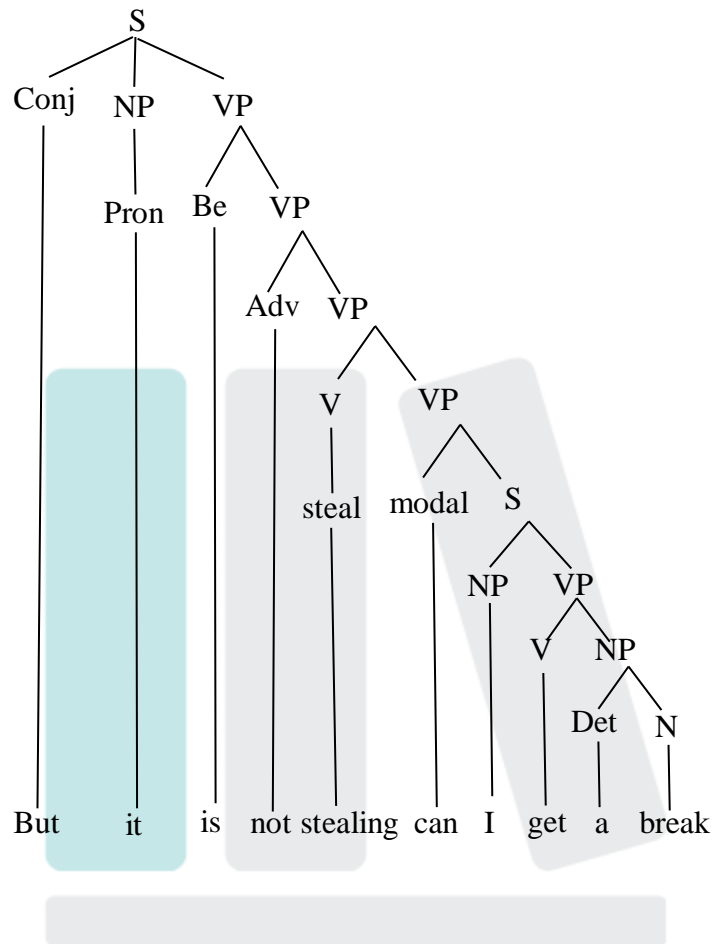

The rules of the tree structure is : $S \rightarrow \text{Conj} + \text{NP} + \text{VP}$

Based on the tree structure, sentence (But it is not stealing, can I get a break?) consist of Conj plus NP plus VP. Conjunction (but) plus Noun Phrase consist of Pronoun (it) plus Verb Phrase consist of Be (is), Adverb (not), Verb (stealing), modal (can), sentence consist of Noun Phrase (I), Verb Phrase consist of Verb (get), Noun Phrase consist of Determiner (a), and Noun (break).

Datum 10:

Non-Standard English	Instrument For Standardizing English Words	Standard English Word
There ain't a better time in the day (line 15)	- Phonological process: Delection of the Negations	There is not a better time in the day

There is not a better time in the day

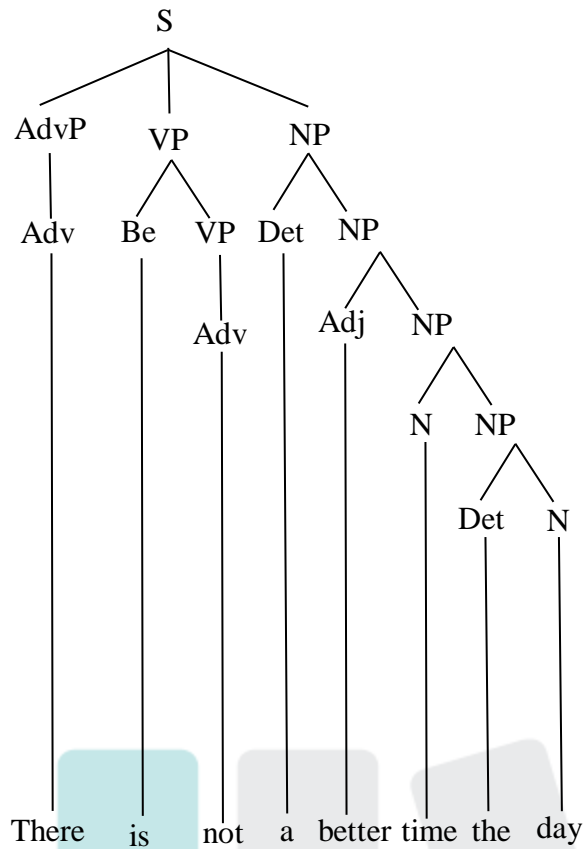

The rules of the tree structure is : $S \rightarrow AdvP + VP + NP$

Based on the tree structure, sentence (There is not a better time in the day) consist of AdvP plus NP plus VP. Adverb Phrase consist of Adverb (there) plus Verb Phrase consist of Verb (is), Adverb (not) plus Noun Phrase consist of Determiner (a), Adjective (better), Noun (time), Determiner (the), and Noun (day).

Datum 11:

Non-Standard English	Instrument For Standardizing English Words	Standard English Word
That's all they wanna hear (line 21)	<ul style="list-style-type: none"> - Phonological process: Delection of the Negations - Phonological process: Assimilation 	That is all they want to hear

That is all they want to hear

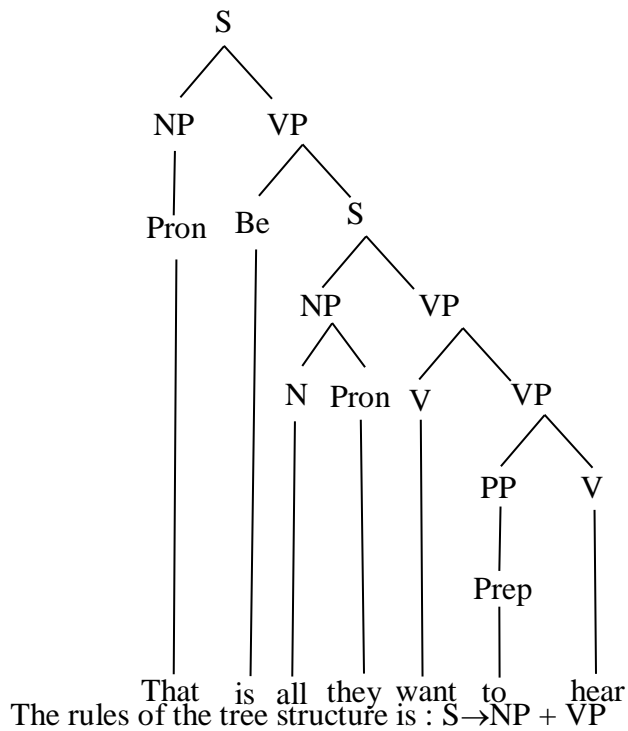

Based on the tree structure, sentence (That is all they want to hear) consist of NP plus VP. Noun Phrase consist of Pronoun (that) plus Verb Phrase consist of Be (is), Sentence consist of Noun Phrase consist of Noun (all) and Pronoun (they) and Verb Phrase consist of Verb (want), Preposition Phrase consist of Preposition (to), and Verb (hear).

Datum 12:

Non-Standard English	Instrument For Standardizing English Words	Standard English Word
When it ain't that bad (line 25)	- Phonological process: Delection of the Negations	When it is not so bad

When it is not so bad

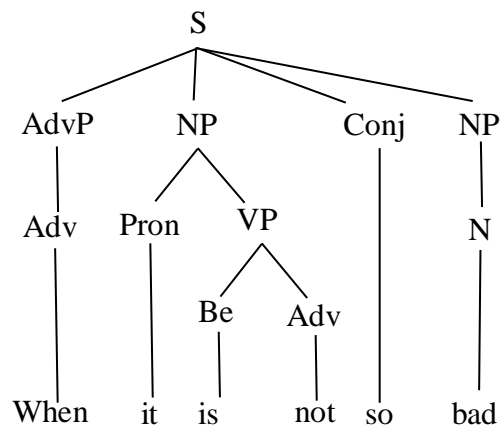

The rules of the tree structure is : $S \rightarrow AdvP + NP + Conj + VP$

Based on the tree structure, sentence (When it is not so bad) consist of AdvP plus NP plus Conj plus VP. Adverb Phrase consist of Adverb (when) plus Noun Phrase consist of Pronoun (it), Verb Phrase consist of Be (is) and Adverb (not) plus Conjunction (so) plus Noun Phrase consist of Noun (bad).

Datum 13:

Non-Standard English	Instrument For Standardizing English Words	Standard English Word
Why I gotta build something beautiful just to go set it on fire? (line 30)	- Phonological process: Assimilation	Why did I gotto build something beautiful just to go set it on fire?

Why did I got to build something beautiful just to go set it on fire?

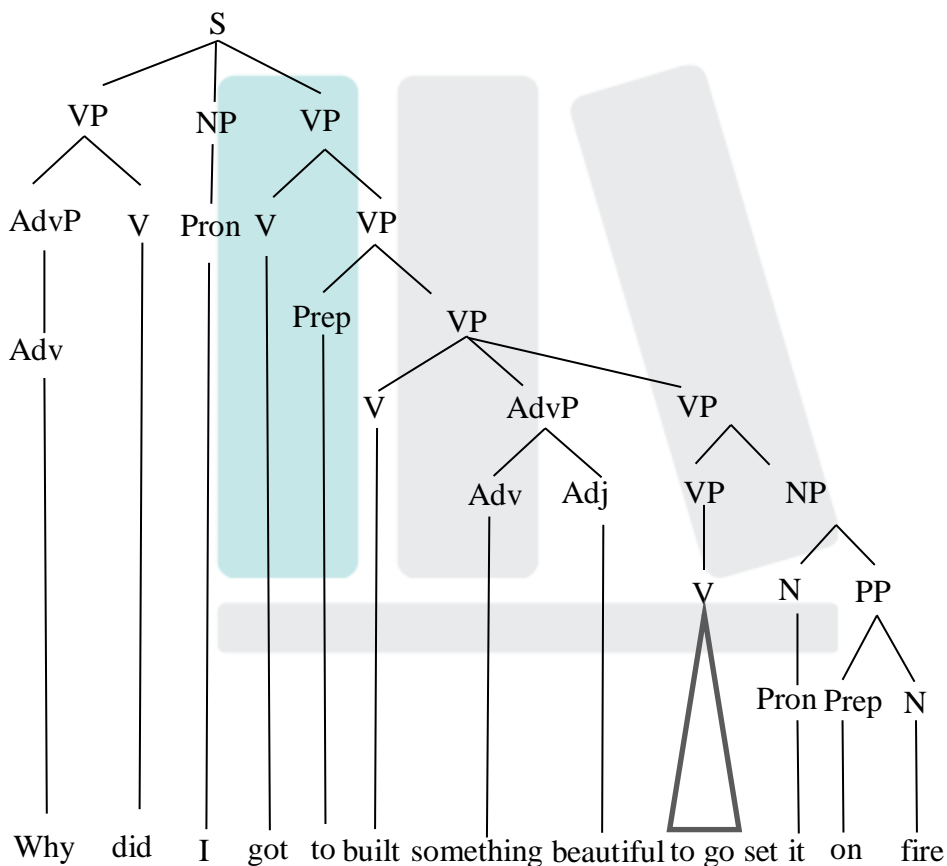

The rules of the tree structure is : $S \rightarrow VP1 + NP + VP2$

Based on the tree structure, sentence (Why did I gotto build something beautiful just to go set it on fire?) consist of VP1 plus NP plus VP2. Verb Phrase1 consist of Adverb Phrase consist of Adverb (why) and Verb (did) plus Noun Phrase consist of Pronoun (I) plus Verb Phrase1 consist of Verb (got), Preposition (to), Verb (built), Adverb Phrase consist of Adverb (something) and Adjective (beautiful), Verb Phrase consist of Verb (to go set), Noun Phrase consist of Pronoun (it), Preposition (on), and Noun (fire).

Datum 14:

Non-Standard English	Instrument For Standardizing English Words	Standard English Word
Maybe 'cause it ain't (line 33)	- Phonological process: Assimilation	Maybe because it is not a liar

Maybe because it is not a liar

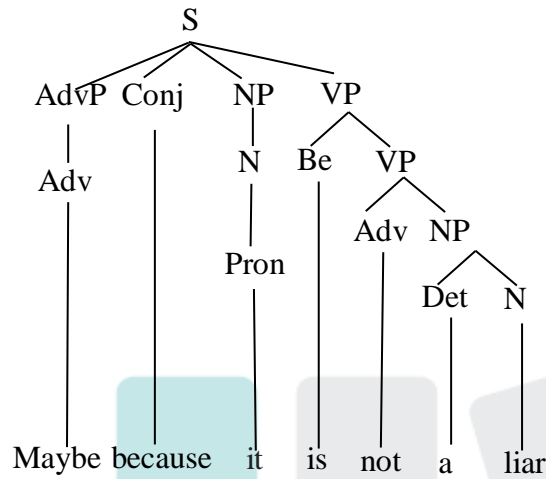

The rules of the tree structure is : $S \rightarrow AdvP + Conj + NP + VP$

Based on the tree structure, sentence (Maybe because it is not a liar) consist of AdvP plus Conj plus NP plus VP. Adverb Phrase consist of Adverb (maybe) plus Noun Phrase consist of Pronoun (it), Verb Phrase consist of Be (is), Adverb (not), Noun Phrase consist of Determiner (a) and Noun (liar).

Datum 15:

Non-Standard English	Instrument For Standardizing English Words	Standard English Word
So what I do? If you know me it ain't anything new (line 35)	- Phonological process: Delection of the Negations	So what I do? If you know me, it is not anything new

So what I do? If you know me, it is not anything new

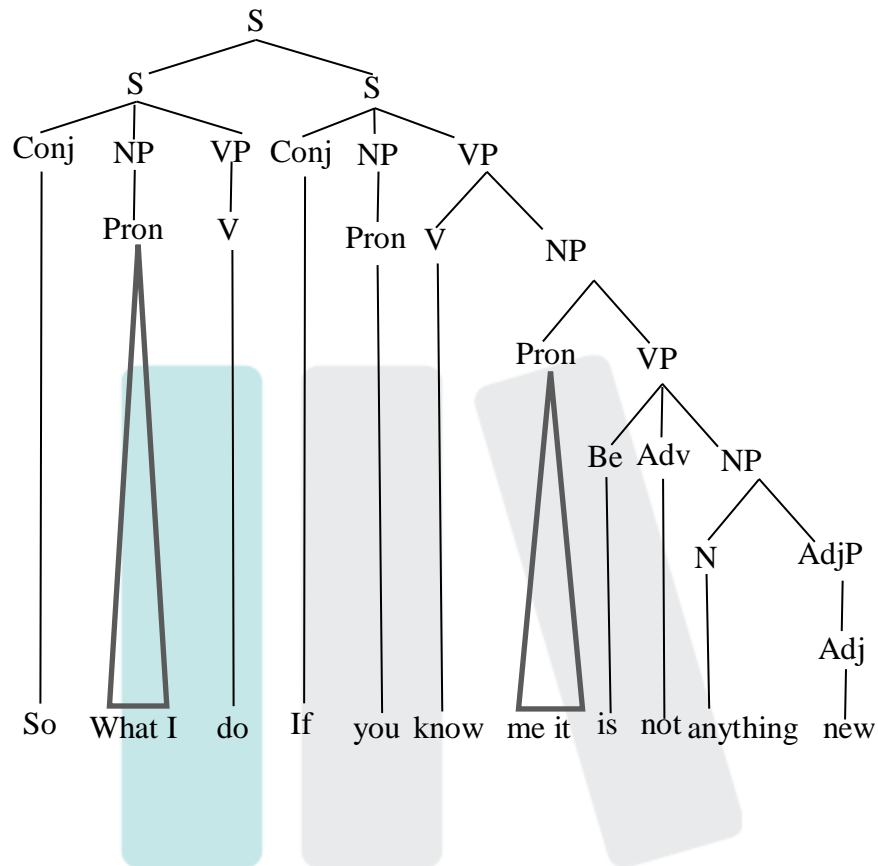

The rules of the tree structure is : S1 → Conj + NP + VP

S2 → Conj + NP + VP

Based on the tree structure, sentence (So what I do? If you know me, it is not anything new) consist of First Sentence consist of Conj plus NP plus VP and Second Sentence Conj plus NP plus VP. First Sentence consist of Conjunction (so) plus Noun Phrase consist pronoun (what I) plus Verb Phrase consist Verb (do). Second Sentence consist of Conjunction (if) plus Noun Phrase consist of Pronoun (you) plus Verb Phrase consist of Verb (know), Noun Phrase consist of Pronoun (me, it), Verb Phrase consist of Be (is), Adverb (not), Noun (anything), and Adjective Phrase consist of Adjective (new).

Datum 16:

Non-Standard English	Instrument For Standardizing English Words	Standard English Word
That it ain't that bad (line 53)	- Phonological process: Delection of the Negations	That it is notso bad

That it is not so bad

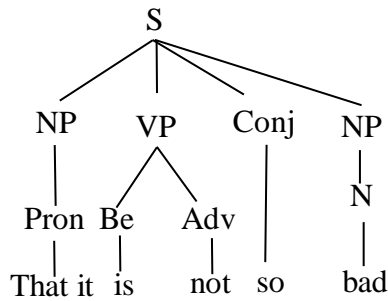

The rules of the tree structure is : $S \rightarrow NP + VP + Conj + NP$

Based on the tree structure, sentence (That it is notso bad) consist of NP plus VP. Noun Phrase consist of Pronoun (that, it), Noun Phrase consist of Be (is), Adverb (not) plus Conjunction (so) plus Noun Phrase consist of Noun (bad).

Datum 17:

Non-Standard English	Instrument For Standardizing English Words	Standard English Word
At least it don't gotta be no more (line 56)	- Phonological process: Delection of the Negations - Phonological process: Assimilation	At least it does not got to be no more

At least it does not got to be no more

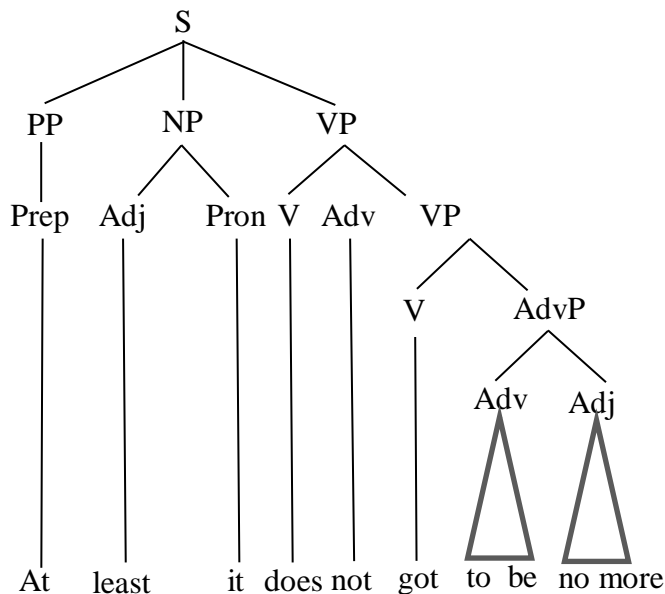

The rules of the tree structure is : $S \rightarrow PP + NP + VP$

Based on the tree structure, sentence (At least it does not got to be no more) consist of PP plus NP plus VP. Preposition Phrase consist of Preposition (at), Noun Phrase consist of Adjective (least), Pronoun (it) plus Verb Phrase consist of Verb (does), Adverb (not), Verb (got), Adverb Phrase consist of Adverb (to be) and Adjective (no more).

DISCUSSION

In analyzing the data, the researcher uses one of the syntactic analyzes, namely the tree structure proposed by Noam Chomsky. Noam Chomsky stated that tree structure shows the hierarchical structure of the sentence. Even though in a sentence there are rules that do not match the specified criteria, it can still be used as a tree structure which is also called the movement rules, proposed by Noam Chomsky. Non-standard English words in the sentence is considered as the basis of the syntactic system, here the writer tries to analyze song data containing non-standard English which is made into standard English by using certain tools to describe sentence structure according to syntax by theory in this study. The writer found on this Mac miller album non-standard English words, such as "ain't, gotta, gonna, wanna, 'fore, 'cause, 'bout, and 'round". There are thirty sentence structure in analyzing Mac Miller song lyric as a sample of this study.

CONCLUSION AND SUGGESTIONS

From the data obtained above, the writer conclude that this study is very important because by studying the field of syntax, especially in sentence structure using a tree structure, which helps solve the details of the sentence structure through more detailed word of word, besides this study also examines how the process of converting non-standard into standard English words, especially for people who do not know much about non-standard English words who want to understand how a non-standard English words that converted into standard English words which will later be useful for understanding its meaning or just having a conversation that uses a lot of non-standard language in the daily life.

Considering the importance of understanding sentence structure, especially in the study of syntax, the writer makes some suggestions.

For students from English Department who will conduct research on the same topic, it is hoped that they can provide a clear understanding of analyzing non-standard English words which are then converted into standard English words in music, especially rap music using syntactic studies.

It is also hoped that there will be other researcher who will conduct studies related to topics from different angles, hoping that there will be new findings related to syntactic studies.

Finally, the author hopes that this thesis can be used as a reference or compare how non-standard English with their daily non-standard language and for those who are interested in studying syntax studies.

REFERENCES

- Aprilia, M, <https://eprints.umm.ac.id/35733/4/jiptumpp-gdl-risyahdars-47742-4-chapter-i.pdf> (Accessed on: February 2, 2022)
- Bagha, Karim Nazari (2011). "A Short Introduction to Semantics". *Journal*. Iran: Islamic Azad University.
- Barekat (2011). "An Introduction to Psycholinguistics". *Journal*. Iran: University of Guilan.
- BBC, "Using Standard and non-standard English", <https://www.bbc.co.uk/bitesize/articles/zp9jkty> (Accessed on: January 29, 2022)
- Betti, Muhammed Jasim (January 19, 2022). "Theoretical and Applied Linguistic". https://www.researchgate.net/publication/347943117_Theoretical_and_Applied_Linguistics.
- Christianto, Danin (2018). "Syntactic Analysis on Sentence Patterns in John Denvers's song lyrics". *Thesis*. Yogyakarta: Sanata Dharma University Yogyakarta.
- Cici, Arfiani et.al. (tt). "An Analysis on Sentence Structure in Paulo Coelho's Novel the Alchemist". *Journal*. Pontianak: Tanjungpura University.
- Dewi, Ida Ayu (2018). "A Study of English Syntactic Sentence Structures of Indonesia Tour guides in Prambanan Temple". *Thesis*. Yogyakarta: Sanata Dharma University Yogyakarta.
- Fuad, Ulfa Muti'ah (2021). "A Syntactic Analysis of Sentence Pattern Used in Westlife's Song Lyrics". *Thesis*. Medan: University of Sumatera Utara.
- Giyatmi (2019). "Morphology for English Language Teaching". *Journal*. Surakarta: Universitas Muhammadiyah Surakarta.
- Haspelmath, Martin and Andrea D. Sims (2010). *Understanding Morphology*. London: British Library.
- Hülya, Mısır (2017). "The analysis of A1 level speaking exam in terms of syntax: The effect of general competence on syntax in A1 level speaking". *Journal*. Turkey: JLLS.
- IAI Al-Qolam Malang (2019). *Pedoman Penulisan Karya Ilmiah, Fakultas Tarbiyah dan Syariah IAI Al-Qolam Malang*. Malang: IAI Al-Qolam Malang
- Khadert, K.T (January 24, 2021) "Definitions of Stylistics". <http://site.iugaza.edu.ps/kkhader/files/2011/10/History-of-STYLE-1.pdf>
- Kim, Jong-Bok and Peter Sells (2008). *English Syntax: An Introduction*. California: Stanford University
- Kreidler, Charles W (2002). *Introducing English Semantic*. London: Taylor & Francis e-Library.
- Ladefoged, Peter N. (August 21, 2014). "Phonetics". <https://www.britannica.com/science/phonetics>.
- Latief, Mohammad Adnan (2019). *Research Methods of Language Learning an Introduction*. Malang: Universitas Negeri Malang.
- Lyric, Dictionary.com, <https://www.dictionary.com/browse/lyric> (Accessed on: October 24, 2021)
- Merriam-Webster.com Dictionary, Merriam-webster, https://dictionary.cambridge.org/dictionary/english/jargon* accessed in February 01, 2022.
- Migdada, Hamzah Faleh et.al. (2020) "A Global View towards Understanding of Standard and NonStandard Varieties of English". *Journal*. Tt: International Journal of Academic Research in Business and Social Sciences.
- Musfiroh, Tadkiroatun (2017). *Psikolinguistik Edukasional*. Yogyakarta: Tiara Wacana.
- Nordquist, Richard (January 21, 2021) "A Crash Course in the Branches of Linguistics". <https://www.thoughtco.com/what-is-linguistics-1691012>
- Nordquist, Richard (January 21, 2022) "Phonology: Definition and Observations". <https://www.thoughtco.com/phonology-definition-1691623>
- Nordquist, Richard (October 24, 2021) "Definition and Examples of Syntax". <https://www.thoughtco.com/syntax-grammar-1692182>

- Nordquist, Richard (Oktober 24, 2021) "Definition and Examples of Syntax". <https://www.thoughtco.com/syntax-grammar-1692182>
- P, Wiyogo and Mulyadi (2019). "A Syntactical Analysis on Sentence Structure Used In Two Adeles's Songs". *Journal*. Madura: Payonara.
- Pamungkas, Salvian Catur (2020). "Syntactic Analysis on Sentence Patterns in "Bahasa Inggris" Text Book for Senior High School". *Thesis*. Ponorogo: Institute of Islamic Studies Ponorogo.
- Peniro, Rocio and Jorde Cyntas (2019). "Applied linguistics theory and application". *Lingcur*, 1.
- Perwata, Ichwan(2008). "A Syntactical Analysis on Sentence Patterns Used in Westlie's Song Lyrics". *Thesis*. Malang: Islamic University Malang.
- Putri, Alfini Iasya (2017). "Linguistics, Literature and Language Teaching". *Journal*. Banjarmasin: UIN Antasari.
- Rizki, Ilham and Zakrimal (2020). "An Analysis Morpheme in Smoking Article". *Journal*. Batam: Universitas Putera Batam.
- Rusmianto, Nurlaksana Eko (2015). *Analisis Wacana Kajian Teoritis dan Praktis*. Yogyakarta: Graha Ilmu.
- Salma, Nurul Fathia (2018). "Exploring Van Dijk: Critical Discourse Analysis's Aims". *Journal*. Riau: Universitas Lancang Kuning.
- Sanda, Toni. "Standard and non-standard English", <https://youtu.be/LzyZujtH4Tg> (Accessed on: January 28, 2022)
- Sapir, Edward (1921). *Language, An Introduction to the Study of Speech*. New York: Harcourt.
- Soleh, Erwan (2015). "A study of Jargon Used by the Community of Dota Gamers in University of Muhammadiyah Malang". *Thesis*. Malang: Muhammadiyah University.
- Suhardi (2020). *Pengantar Linguistik Umum*. Yogyakarta: Ar-Ruzz Media.
- Tariq, Mohammad (2018). "Style, stylistics and stylistic analysis: A re-evaluation of the modern-day rhetorics of literary discourse". *Journal*. India: Integral University.
- Thofan V et.al. (2011). *Buku Ajar Sociolinguistik*. Malang: FKIP Unikama.
- Wikipedia The Free Encyclopedia, Mac Miller, https://en.wikipedia.org/wiki/Mac_Miller (Accessed in January 24, 2022).
- Wirantari, Agustina Ike (2008). "The Use of Contracted Forms in The Hip-Hop Song Lyrics". *Thesis*. Yogyakarta: Sanata Dharma University
- Yanti, K. E et.al. (2018). "The Phonological Sytem of Kutuh Dialect: A Descriptive Study". *Journal*. Buleleng: Universitas Pendidikan Ganesha.
- Yossa, Lily Gusti and Jufrizal (2012). "Phonetic Characteristics of English Pronunciation Delivered by Joko Widodo at The Apec Ceo Summit 2014: An Acoustic Phonetic Study on Suprasegmental Features". *Journal*. Padang: E-Journal English Language and Literature.